

# **Shaheed Smarak College**

## **SSR REPORT 2019**

**Bharatpur-19, Bakhanpur, Sharadanagar, Chitwan, Nepal**

## **FOREWORD**

This college is established in the memory of the martyrs of Sharadanagar and its peripherals who sacrificed their lives for the nation. The main motive of this establishment is to impart quality education with the facilities of modern technology to the students of different races, castes, economic status and from Dalits, indigenous groups, women, etc. This college is established with the new concept that if the education becomes cheap and available to all, then only there is the possibility of welfare of people, society and the nation which will thus become an effort for the nation building process. So, the college offers different faculties with multiple subjects to meet such objectives.

The locality of the college consists of indigenous groups, Dalits, backward people, etc. which is away from the reach of education. However, there are the families of ex-armies from Indian and British armies. As such community is deprived of education; this college has a vital role to make education accessible to the community. This aims basically to uplift the standard of the education so that the graduates who pass out from here would have the closer access to the labor market and hence they would uplift their socio-economic level.

This graduate tracer study is mainly a survey intended to trace graduates from their school of origin to their place of employment or self-employment. To obtain the needed information, the questionnaires developed by the UGC were used which served as the data gathering instrument.

## **ACKNOWLEDGMENT**

Tracer study Task tem acknowledges all the respondents who participated in the survey. We also wish to thank the examination, library and Account section for providing the Population and for supporting the administration of the survey

## **EXECUTIVE SUMMARY**

### **IMPORTANCE OF GRADUATE TRACER STUDIES**

Graduate Tracer studies constitute an important tool for educational planners, as they can provide valuable information for evaluating the results of the higher education and training institutions. This information may be used for minimizing any possible deficits in a given educational program in terms of content, delivery and relevance and for further development of the institution in the context of quality assurance.

### **COVERAGE OF THE TRACER STUDY**

The present Graduate Tracer Study was launched by the Tracer study committee of SSC in the 1<sup>st</sup> quarter of 2019. It targeted a number of 17 graduates of the Faculties of Education and Management of the year 2018.

### **OBJECTIVES OF THE TRACER STUDY**

The main objectives of the study were to trace the destination of the graduates since they left university with a view to establish among others their current activity, utilization of skills, the level of employment, unemployment and underemployment, labor mobility and job satisfaction. The survey also aimed to assess the contribution of the university training to graduates personal development as well as the quality of the program of study in terms of content, delivery and relevance to the world of work. Specifically these are the main objectives of the tracer study

### **SURVEY METHODOLOGY**

The study made use of a survey questionnaire, comprised of some 8(A-H) questions, drawn from a record of students, which provided details of the names and addresses of graduates by program of study and year of graduation. Questionnaires were sent to the graduates in the sample list, together with a covering letter and a stamped addressed envelope for return, explaining the objectives of the study.

## **SURVEY IMPLEMENTATION**

The survey was launched in the 1st quarter of 2019, with the closing date set for the last quarter of 2019. A copy of the questionnaire was handed to all the graduates concerned, together with a covering letter and a stamped addressed envelope for return, explaining the objectives of the study. Follow-up letters were issued time to time to non-respondents. As a result, the response rate was increased to a higher extent and all the filled up questionnaires were returned by the 2nd week of November, 2019.

## **COHORT**

The characteristics of respondents in relation to the sample showed the same kind of representation of 2018.

## **FACULTY/FIELD**

At the level of faculty, the responses were quite representative of the sample: Management- 57% and Education 43% as the sample and the responses were quite the same.

## **AGE**

The mean age of respondents stood at 24.91 years, with an average of 23.6 years for the Management and 26.6 years for the Education Faculties.

## **GENDER**

A high degree of correspondence was observed between the gender characteristics of respondents and that of the sample, with female constituting 79% of responses as opposed to 21%.

## **Cast wise DISTRIBUTION**

The distribution of respondents by cast wise is noted as follows. 28.5% of respondents belonging to brahmin , 36% gurung , 14.2% chhetri , 14.2% Tamang and 7.1% Dalit graduates is found.

## **GRADUATES' FURTHER STUDIES**

Quite a high percentage of respondents or some 28.5% had undertaken or were undertaking further studies, after they were awarded their undergraduate degree. All of these are Management graduates.

## **GRADUATES' CAREER ASPIRATIONS AND ACHIEVEMENTS**

Only 28.5 % (4 out of 14) of respondents were job holder. 50% (2 out of 4) of job holder respondents were contemplating a career in teaching and 25% Accountant , 25% employed in NGO Whereas 71.5% of the respondents were still in search of job.

## **GRADUATES' ECONOMIC STATUS**

Out of job holder respondents 100% were full time and none of part time job holders. 71.5% of respondents, on the other hand, were economically inactive, i.e., they were not working and were not available for paid work.

## **OCCUPATIONAL DISTRIBUTION OF GRADUATES' EMPLOYMENT**

Graduates in both the Management and Education were on the labor market. 21.43 % (3 of 14) were found involved in the private sector and 7.14 % were found employed in the government sector and were not found working in the other sectors.

## **GRADUATES' EMPLOYMENT IN PRIVATE V/S OTHER SECTOR**

On the whole, 75% of the job holders are involved in the private sector and 25% in the Government sector.

## **GRADUATES' ASSESSMENT OF THE QUALITY OF THEIR PROGRAMMES OF STUDY**

Respondents, in general, acknowledged the positive contribution of the program of study to their personal development. Eleven core skills were assessed in this context, namely Relevance of the program to your professional requirements, extracurricular activities, problem solving ability, work placement/attachment/internship, Teaching/ learning environment, quality of education delivered, teacher students relationship, library facility, lab facility, sports facility, canteen/urinals .66.9% of responses overall endorsed the positive contribution of the programs of study to graduates' personal development.

### **Relevance of the program to your professional requirements**

An overwhelming majority of respondents 64.2% admitted that the program of study is relevance to their professional requirements.

### **Extracurricular activities**

58.5% respondents accepted that the extracurricular activity is the part of their program of studies.

### **Problem Solving Ability**

Some 61.43% endorsed the view that their problem-solving skills had improved, with an decrease in satisfaction registered BBS and BED as follows: BBS 62.5%, BED 60%.

### **Work placement/attachment/internship**

The contribution of the program of study to graduates' to work placement/attachment/internship was 60 % . In faculty wise BBS and BED as follows: BBS 62.5%; BED 56.6%.

## **Teaching/ learning environment**

Similar trend as above was observed regarding the contribution of the program of study to graduates' by teaching/ learning environment as follows: BBS 87.5%; BED 50%.

## **Quality of education delivered**

Some 67.14% of respondents noted that the program of study enhance their quality of education delivered.

## **Teacher student's relationship**

Overall 82.8% of favorable opinion was expressed with regard to Teacher student's relationship Of the program of study.

## **Library facility**

Only 57.14% of respondents' graduates express as favorable opinion with regard to library.

## **Lab facility**

Only 45.7 % of respondents' consider as a strength of their program of study with regard of lab facility.

## **Sports facility**

Overall 62.8%of respondents' consider as strength of their program of study with regard of sports facility.

## **Canteen/urinals**

Over all 58.57% respondents graduates are satisfied to canteen/urinals facilities.



## **SUGGESTION OF THE RESPONDENTS**

Out of 14 respondents, 14.29% suggested for the improvement in the teaching learning activities, 28.57% in increment of library facilities, 28.57% Canteen facilities, 7.1% suggest to enhance the lab, and 7.1% respondents emphasize pure drinking water facilities.

## **ASSURANCE OF SUPPORT FROM THE RESPONDENTS**

The result on this showed that the highest percentage (37.7%) of respondents purposed for create scholarship fund for needy student, 7.1% support through Alumni ,support of teaching materials (7.1%).where as it was less in others such as financial support (35.7%),and donate unused book (7.1%).

## TABLE OF CONTENTS

<b>LIST OF TABLES</b>	<b>II</b>
<b>LIST OF FIGURES</b>	<b>IV</b>
<b>LIST OF ACRONYMS</b>	<b>V</b>
<b>FOREWORD</b>	<b>VI</b>
<b>EXECUTIVE SUMMARY</b>	<b>VII</b>
<b>Chapter 1:</b>	
<b>1.1 Introduction</b>	
<b>1.2 Background</b>	
<b>1.3 Objective of the study</b>	
<b>1.4 Institutional arrangements to conduct the study</b>	
<b>1.5 The survey Questionnaire</b>	
<b>1.6 Graduate batch taken for the study</b>	
<b>1.7 Data collection and survey Implementation</b>	
<b>1.8 Data processing and Analysis</b>	
<b>1.9 Scope and Limitation of the study</b>	<b>1</b>
<b>Chapter 2:</b>	
<b>Data Presentation and Analysis</b>	
<b>2.1 Graduates personal profile</b>	
<b>2.2 Issue related to the employment status and further study OF GRADUATES</b>	
<b>2.3 The assessment of graduates on quality measures of ssc</b>	
<b>2.4 Suggestion, recommendation and contribution of graduates for the betterment of institution.</b>	

**Chapter 3:**

**Major Findings**

**3.1 Graduates personal profile**

**3.2 Issue related to the employment status and further study of graduates**

**3.3 The assessment of graduates on quality measures of ssc**

**3.4 Suggestion, recommendation and contribution of graduates for the betterment of institution.**

**Chapter 4:**

**Implications to Institutional Reform**

**37**

**Chapter 5:**

**Conclucation and Recommendations**

**38**

**Annex :**

**Questionnaire**

## LIST OF TABLES

**Table 1: Distribution of graduates by Gender**

**Table 2: Distribution of Respondents by Faculty**

**Table 3: Respondents by Age/Faculty**

**Table 4: Distribution of Graduates by Cast**

**Table 5: Respondents Pursuing/Pursued Further Education v/s Total Number of Respondents by year**

**Table 6: Cast wise/faculty wise Respondents to find a Job**

**Table 7: Graduates' Current Occupations**

**Table 8: Respondents' Employment Distributed by Sector**

**Table 9: Types of Work**

**Table 10 Assessment of quality of the Program of Study**

**Table 11 Assessment of quality of the Program of Study**

**Table 12: Graduates' Assessment of the Contribution of the Program of Study**

**Table 13: Relevance of the program to your professional requirements**

**Table 14 Extracurricular activities**

**Table 15: Problem solving ability**

**Table 16: Work placement/ attachment/ internship**

**Table 17: Teaching/ learning environment**

**Table 18: Quality of education delivered**

**Table 19: Teacher Student relationship**

**Table 20: Library facility**

**Table 21: Lab facility**

**Table 22: Sports facility**

**Table 23: Canteen / Urinals etc**

**Table 24: Suggestion and recommendation of graduates for betterment of the college.**

**Table 25: Possible Contribution of Graduates for the Betterment of the College**



## **LIST OF FIGURES**

- Figure 1: Distribution of respondents by Gender**
- Figure2: Distribution of Respondents by Faculty**
- Figure3: Respondents by age**
- Figure 4: Distribution of Graduates by Cast**
- Figure5: Respondents Pursuing/Pursued Further Education v/s Total Number of Respondents by year**
- Figure 6 :Cast wise Respondents to find a Job**
- Figure 7: Graduates' Current Occupations**
- Figure 8: Respondents' Employment Distributed by Sector**
- Figure 9: Types of Work**
- Figure 10: Contribution of Program of Study of Graduate**
- Figure 11: Assessment Based on Relevance of the program to professional requirements**
- Figure 12: Extracurricular activities**
- Figure 13: Problem solving ability**
- Figure 14: Work placement/ attachment/ internship**
- Figure 15: Teaching/ learning environment**
- Figure 16: Quality of education delivered**
- Figure 17: Teacher Student relationship**
- Figure 18: Library facility**
- Figure 19: Lab facility**
- Figure 20: Sports facility**
- Figure 21: Canteen / Urinals etc**
- Figure 22: Suggestion and Recommendation of Graduates for betterment of the college**
- Figure 23: Possible Contribution of Graduates for the Betterment of the College**

## **LIST OF ACRONYMS**

**B.B.S. - Bachelor of Business Studies**

**B.Ed. - Bachelor of Education**

**B.S. - Business Sector**

**F - Female**

**G.S. - Government Sector**

**IT - Information Technology**

**M - Male**

**M.B.S. - Master of Business Studies**

**M.Ed. - Master of Education**

**MGT - Management**

**NGO - Non-Government Organization**

**S.E. - Self-Employed**

**SSC – Shaheed Smarak College**

**T – Total**

**UGC - University Grant Commission**

## CHAPTER 1

# Introduction

### 1.1 Background

Educational institutes which are located in the rural areas with limited resources are really challenging to be managed properly. These institutes are to educate the pupils from those families which have very low economic status in the society. In the present context of 21<sup>st</sup> Century with high-tech facilities in education systems, we still are following traditional systems in teaching-learning activities. We have resource constraints in one hand and in another we have to fulfill the expectations of stakeholders. So this study is basically focused to find out the real scenario of the present situation of the labor market, skills they need and the expertise that employers require.

### 1.2 Objectives of the study

This Graduate Tracer Study 2019 aims at finding the relationship between higher education and the labor market in Nepal and abroad. It is based on considerations of the experiences of the SSC graduates.

The Study has following specific objectives:

- a) To find graduates personal profile
- b) To explore the employment status and further study of the graduates
- c) To assess by graduates on quality measures of ssc
- d) To suggest, recommend and contribute of graduates for the betterment of institution.

The study is designed to provide relevant information, both quantitative and qualitative, to educational planners and policy makers to assist them to make informed decisions and fine-tune their strategies, in view of meeting the country's high-level and skilled human resource needs.



### ***1.3 Institutional arrangements to conduct the study***

SSC has dedicated team that prepares and publishes this report on regular basis. This study is basically focused to find out the real scenario of the current employment status, present situation of the labor market, skills they need and the expertise that employers require.

### **1.4 Methodology**

The methodology adopted for the study consisted of a survey questionnaire (Annex 1) which was provided by the UGC and other reference used in similar study undertaken by different educational institutions in Nepal. However the same questionnaire was discussed at the level of the Senior UGC personnel and the Community Campus chiefs in the program organized by the UGC, Nepal and finalized.

### **1.5 The Survey Questionnaire**

The questionnaire comprised some 8 (A-H) questions which were further categorized into 4 broad themes as follows:

#### **i) Graduates personal profile**

- ❖ the characteristics of graduates
- ❖ providing information of age, gender, program, address of graduates

#### **(ii) Issue related to the employment status and further study of graduates**

- ❖ the transition from College to the labor market
- ❖ Graduate's further study
- ❖ the characteristics and nature of the unemployed graduates
- ❖ nature of employment
- ❖ the occupational and sectorial distribution of graduate employment

### **(iii) The assessment of graduates on quality measures of ssc**

- ❖ Major strength and weaknesses of the quality of educational delivered, the teaching and learning environment, teacher-student relationship and library and lab.
- ❖ the course content including the extent of problem solving ability, sports and canteen/urinals facilities
- ❖ The course relevance including the relevance of the program to professional requirement, extracurricular activities and the importance of work placement.

### **iv) Suggestions, recommendation and contribution of graduates for the betterment of institution**

- ❖ Enhancing the college by giving suggestion, recommendation and contribution by graduates

## **1.6 Graduate batch taken for the study**

The Survey targeted BBS and BED full-time graduates over the period 2018. It made use of sample, stratified by cohort, gender and place of residence, drawn from a list of graduates obtained from the college, which provided details of names and addresses of graduates by field and year of graduation. In total 14 graduates (BBS- 8; BEd- 6) were covered by the survey and all of them provided the data.

## **1.7 Data Collection and Survey Implementation**

The survey was launched in the first quarter of 2019, with the closing date set for the first quarter of 2019. A copy of the questionnaire was handed to all the graduates concerned, together with a covering letter and a stamped addressed envelope for return, explaining the objectives of the study. Follow-up letters were issued time to time to non-respondents. As a result, the response rate was increased to a higher extent and all the filled up questionnaires were returned by the last week of November, 2019.

## **1.8 Data Processing and Analysis**

The data collected were edited, coded and inputted on an MS Database Access. Data analysis was done in Excel. The analysis of the survey data took longer than expected, owing to numerous attempts made during the process to improve the structure of reporting and enhance the quality and level of analysis. The real students were contacted by phone for the further clearance of the data.

## **1.9 Scope and Limitation of the study**

This study aims will cover all BBS and BED graduates whether studying, working aboard or in locally based companies who graduated from year 2018 only to allow the graduates enough time to find employment. It aims to cover all graduates in local as well as aboard residing.

## CHAPTER 2

### DATA PRESENTATION AND ANALYSIS

This chapter is described into four major Section. The first section deals graduates personal profile, Second Employment status and further study, third the assessment on quality measures of SSC and fourth section is presents the suggestion, recommendation and contribution of graduates for the betterment of institution.

#### 2.1 Graduates personal profile

This section examines the characteristics (age, gender, place of residence, etc.) of respondents.

**Table1: Distribution of graduates by Gender**

Gender	Respondents	
	No. (B)	(% Share)
Male	3	21
Female	11	79
Total	14	100

Field Survey 2019

The survey targeted to full-time Bachelor's Degree graduates of Shaheed Smarak College of 2018 batch, equivalent to 14 graduates including male 3 (21%) and 11(79%) female graduates. These statistics showed that female respondents were more than male (Table 1).

**Figure 1: Distribution of respondents by Gender**

The following figure shows gender of the respondents

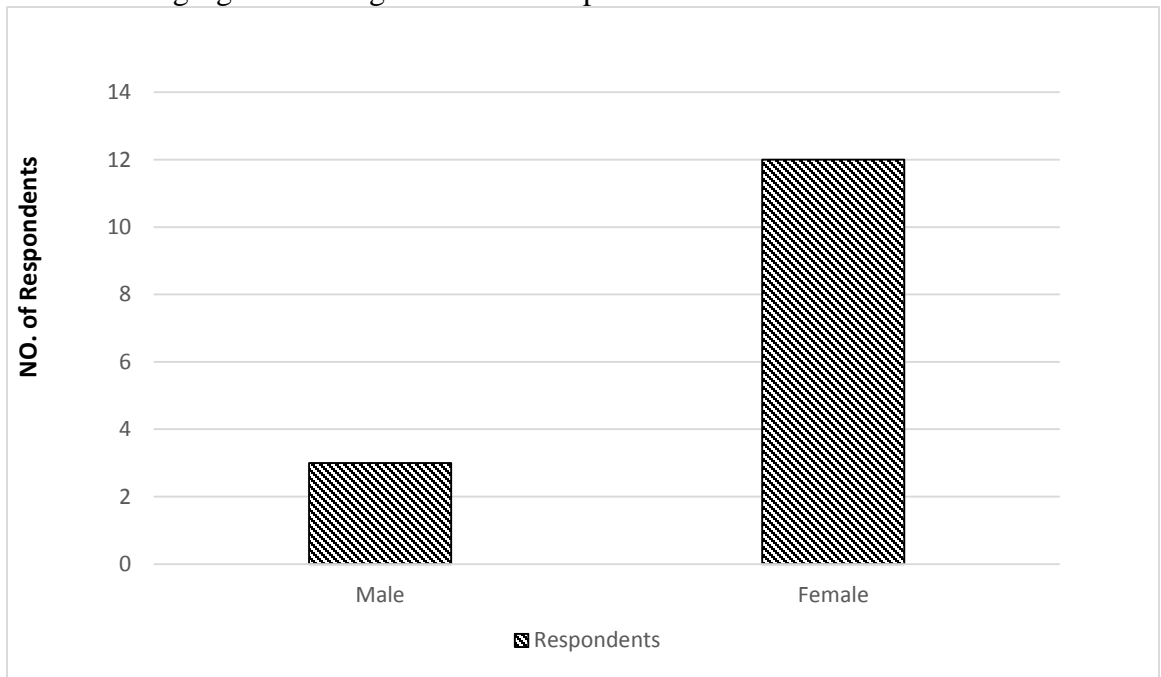

2. In all, 14 graduates participated in the survey 8(57.0%) were from the Management Faculty and 6 (43.0%) from the Education Faculty respectively (Table 2)

**Table 2: Distribution of Respondents by Faculty**

Year	Bachelors		Management		Education	
	No.	Total %	No	%	No	%
2017	14	100	8	57	6	43

Field Survey 2019

**Figure2: Distribution of Respondents by Faculty**

The following figure shows faculty of the respondents

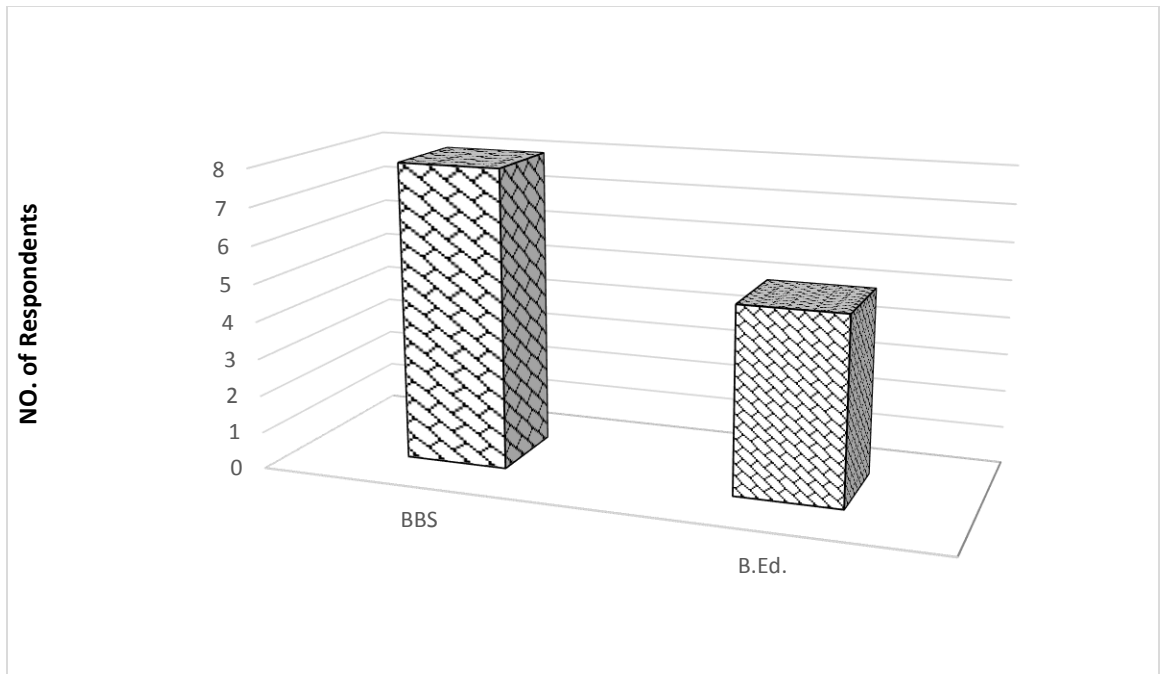

**Table 3: Respondents by Age/Faculty**

<b>Age Group (yrs)</b>	<b>Bachelor</b>		<b>BBS</b>		<b>BED</b>	
	No.	%	No.	%	No.	%
20-25	8	57	7	87.5	1	17
25-30	5	36	1	12.5	4	66
30-35	1	7	0	0	1	17
Total	14		8		6	
Ave Age	24.9		23.6		26.6	

Field Survey 2019

The mean age of respondents was found at 24.9 years, with Education graduation being on average slightly older than Management ones, or 26.6 years compared with 23.6 years. 57 % of respondents were in the age group 20-25 years; 36 % between 25-30 years, 7% between 30-35 (Table 3)

The following figure shows age of the respondents

**Figure 3: Respondents by Age**

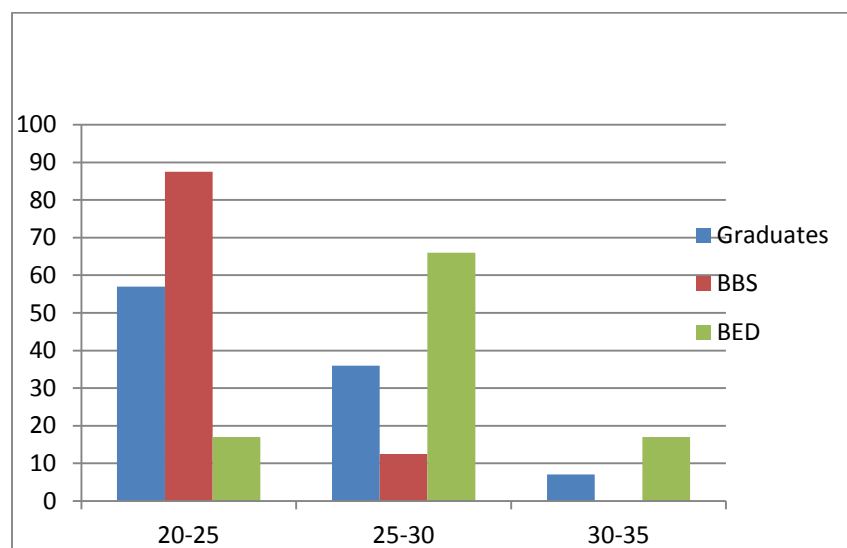

**Table 4: Distribution of Graduates by Cast**

Cast	Total	
	No.	%
Brahmin	4	28.5
Gurung	5	36
Chhetri	2	14.2
Tamang	2	14.2
Dalit	1	7
Total	14	

Field Survey 2019



Table shows that out of the total respondents, 50.2% percent were found from janajati followed by Brahmin 28.5, 14.2% chhetri and 7 percent from others. Janajati includes Gurung, Tamang. Similarly Upper cast includes Brahmin and chhetri. (Table 4)

This figure shows cast of the respondents

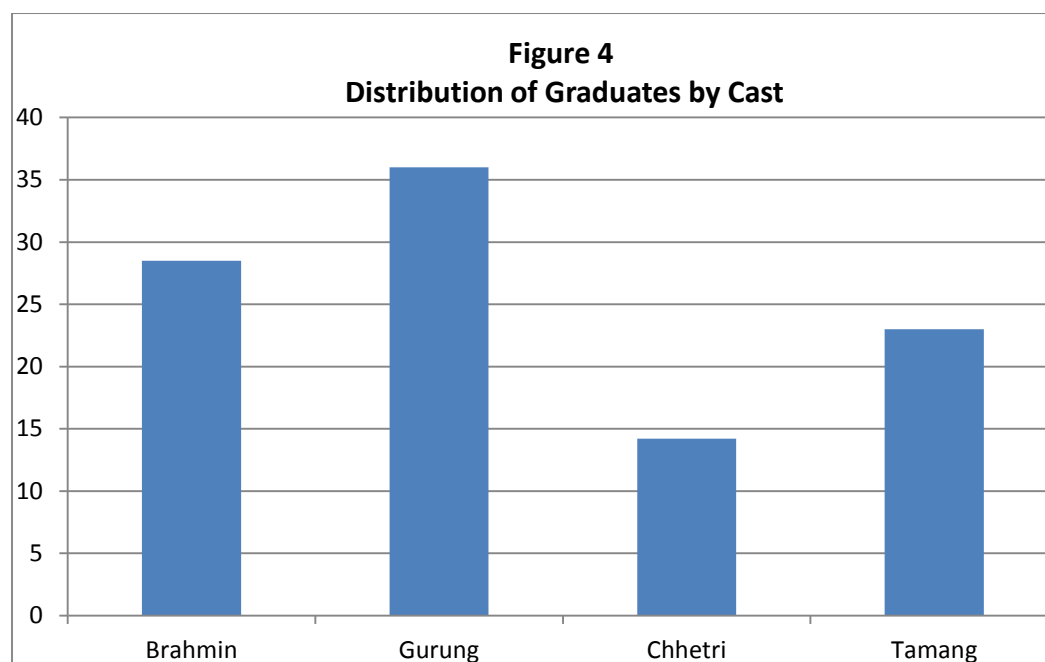

Field survey 2019

## 2.2 ISSUES RELATED TO THE EMPLOYMENT STATUS and further study OF GRADUATES

This section examines the nature and extent of mismatch between graduates' career aspirations and achievements, their transition from university to the world of work, their experience and status with regard to employment, unemployment and underemployment and further study.

**Table 5: Respondents Pursuing/Pursued Further Education v/s Total Number of Respondents by year**

Year	Total			BBS			B.Ed.		
	Total No. (A)	B	(B/A) %	Total No. (A)	B	(B/A) %	Total No. (A)	B	(B/A) %
2018	14	4	28.5	8	4	50	5	0	0

A-Number of respondents

Field survey 2019

B-No. of respondents pursuing/pursued further studies From the table above, it is found that out of total (14), 28.5 percent enrolled for further study. Out of enrolled respondents (4), 100 percent are enrolled in BBS. This concerned a majority of graduates choose management.(Table 5)

The following figure shows further study of the respondents

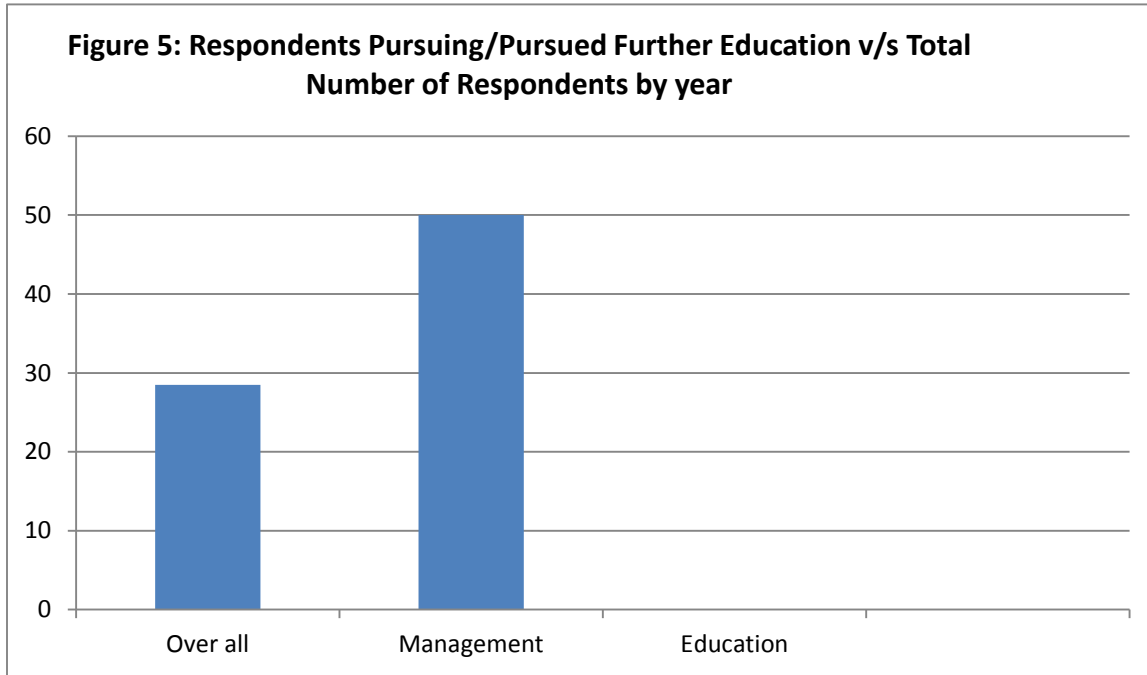

Field survey 2019

**Table 6: Cast wise/faculty wise Respondents to find a Job**

Cast	Total		BBS		B.Ed.	
	No.	%	No.	%	No.	%
Brahmin	1	25	0	0	1	50
Gurung	1	25	1	50	0	0
Chhetri	1	25	1	50	0	0
Dalit	1	25	0		1	50
Total	4		2		2	

Field survey 2019

Table 6 shows that out of the total employed respondents (4), 50 percent were found from upper caste followed by janajati 25 and 25 percent from dalit (Table 6)

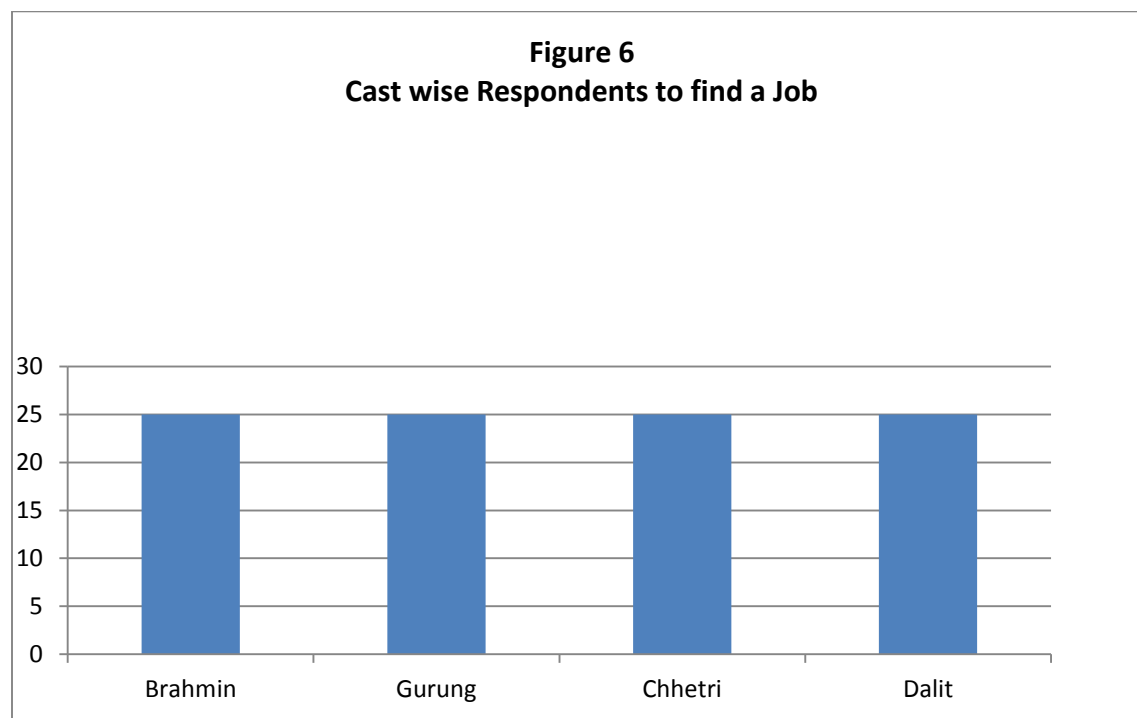
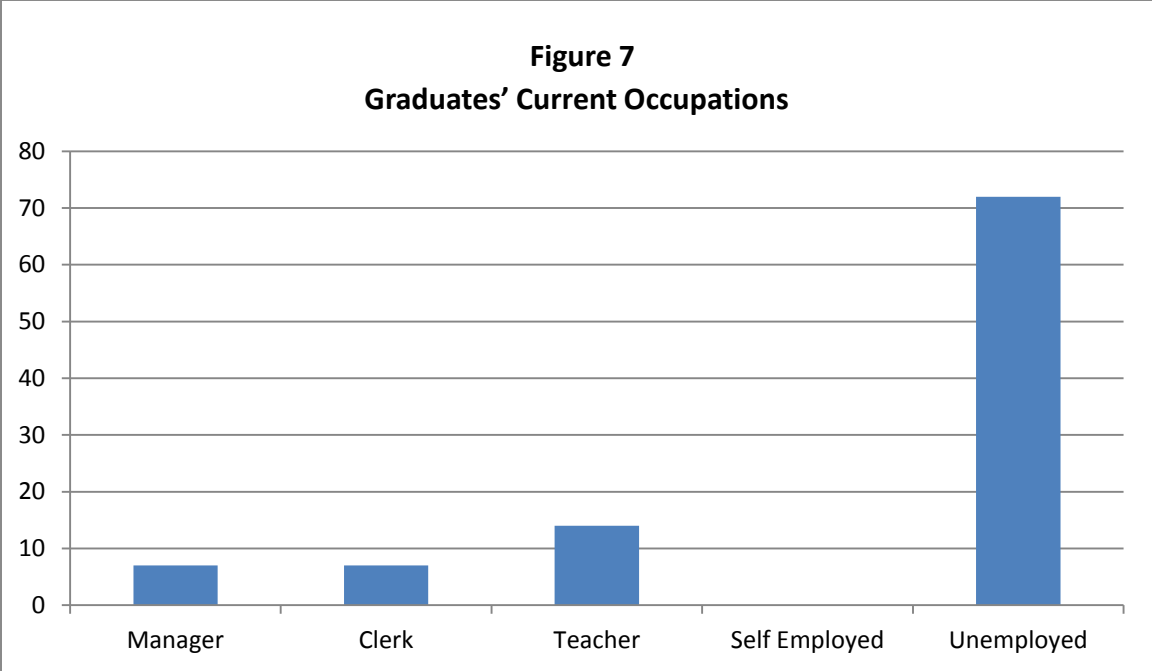

**Table 7: Graduates' Current Occupations**

<b>Current Occupation</b>	<b>Total</b>		<b>BBS</b>		<b>B.Ed.</b>	
	<b>No.</b>	<b>%</b>	<b>No</b>	<b>%</b>	<b>No</b>	<b>%</b>
Manager	1	7	1	12.5	-	-
Clerk	1	7	0	0	1	20
Teacher	2	14	1	12.5	1	20
Self Employed	0	0	0	0	-	
Unemployed	10	72	6	75	3	60
Total	14		8		6	

Field survey 2019

Majority of Graduate are unemployed ie 72% of Graduate. Only 28% graduates have a job, all of which were in service sector such as Manager 7%,Clerk 7% and Teacher 14%. Out of employed graduate (2 of 4) 50% are Management faculty, similar in education faculty. (Table 7)

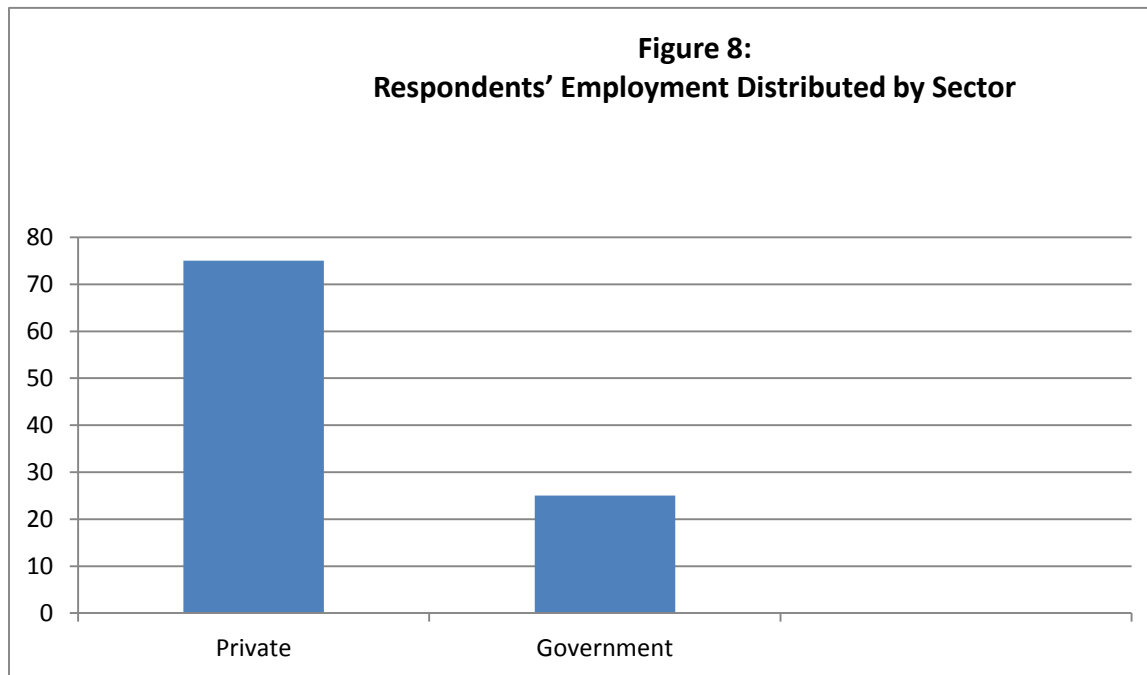

**Table 8: Respondents' Employment Distributed by Section**

Sector	Total		BBS		B.Ed.	
	No.	%	No	%	No	%
Private	3	75	2	100	1	50
Government	1	25	0	0	1	50
Total	4		2		2	

This table reveals that out of total employed graduates 75% of graduates were working in the private sector and 25 % in the Government sector. (Table 8).

The following figure shows employment status of the respondents by sector



**Table 9: Types of Work**

	Total		BBS		B.Ed.	
	No	%	No	%	No	%
Full Time	4	28.5	2	25	2	40
Part Time	-	-	-	-	-	-
Total	4		2		2	

This table shows that out of total employed respondents, 100% of respondents surveyed were working full-time, None were working part-time .(Table 9).

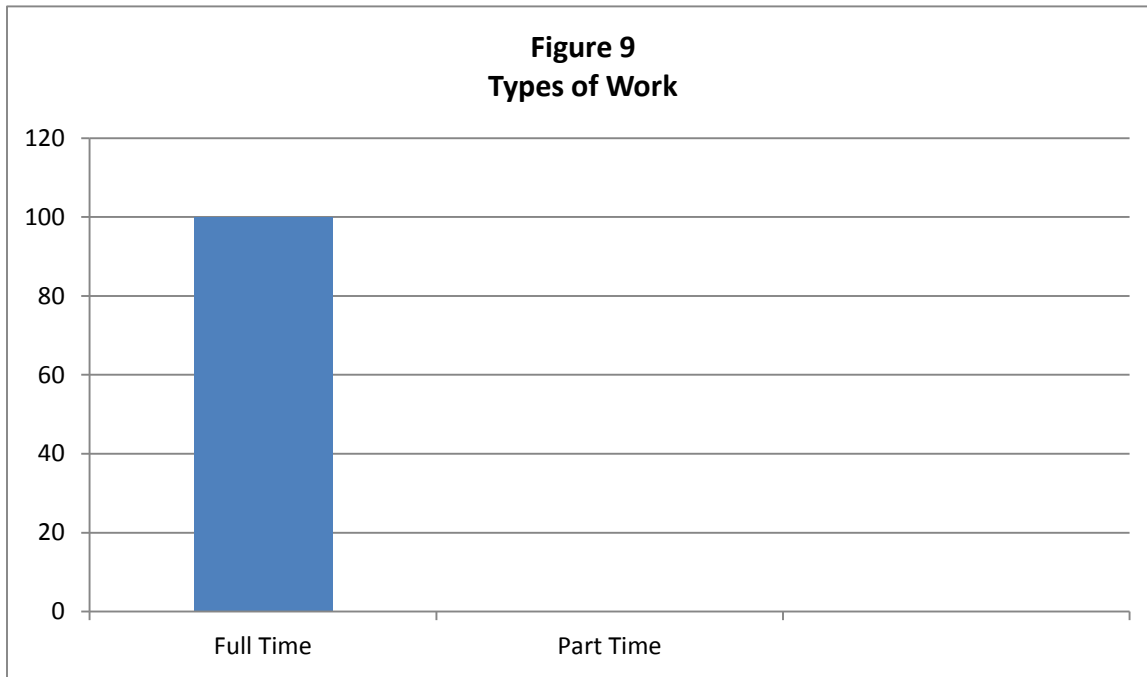

Field survey 2019

### 2.3 The assessment of graduates on quality measures of SSC

This Chapter tries to assess with the perceived value regarding quality measures of different dimensions of the institution. It describes the rating of graduates on different variables of the institution relating with its quality education delivery mechanism. This study incorporates eleven specific variables to evaluate the institutions strengths and weaknesses from the point of view of graduates.

These tables try to assess with the perceived value regarding quality measures of different dimensions of the institution

**Table 10 Assessment of quality of the Program of Study**

Particulars	Overall
-------------	---------

	%
Relevance of the program to your professional requirements	64.20
Extracurricular activities	58.57
Problem solving ability	61.43
Work placement / attachment / internship	44.28
Teaching/ Learning environment	67.14
Quality of education delivered	37.14
Teacher student relationship	82.80
Library facility	57.14
Lab facility	45.70
Sports facility	62.80
Canteen / Urinals etc	58.57
Average	57.00

Field survey 2019



**Table 11 Assessment of quality of the Program of Study**

Particulars	BBS	BED	Overall
	%	%	%
Relevance of the program to your professional requirements	65.00	63.30	64.20
Extracurricular activities	55.00	63.30	58.57
Problem solving ability	62.50	60.00	61.43
Work placement / attachment / internship	40.00	50.00	44.28
Teaching/ Learning environment	87.50	50.00	67.14
Quality of education delivered	35.00	40.00	37.14
Teacher student relationship	80.00	86.67	82.80
Library facility	57.50	56.60	57.14
Lab facility	50.00	40.00	45.70
Sports facility	62.50	63.30	62.80
Canteen / Urinals etc	60.00	56.60	58.57
Average	63.6	51.90	57.00

Field survey 2019

**Table 12: Graduates' Assessment of the Contribution of the Program of Study**

Cohort	1	2	3	4	5	6	7	8	9	10	11	Overall
		64.20	58.57	61.43	44.28	67.14	37.14	82.80	57.14	45.70	62.80	58.57
<b>BBS</b>												
2018	65.00	55.00	62.50	40.00	87.50	35.00	80.00	57.50	50.00	62.50	60.00	63.60
<b>B.Ed.</b>												
2018	63.30	63.30	60.00	50.00	50.00	40.00	86.67	56.60	40.00	63.30	56.60	51.90

The quality of instruction received by graduates was assessed on the basis of 11 indicators relating to the content, (Relevance of the program to your professional requirements, extracurricular activities, problem solving ability, work placement/attachment/internship, Teaching/ learning environment, quality of education delivered, teacher students relationship, library facility, lab facility, sports facility, canteen/urinals) of the program of study (Table 10-11) Overall, 57.0% of favorable opinions was expressed with regard to the quality of the program of study.

This figure shows the assessment of the graduates with the perceived value regarding quality measures of different dimensions of the institution

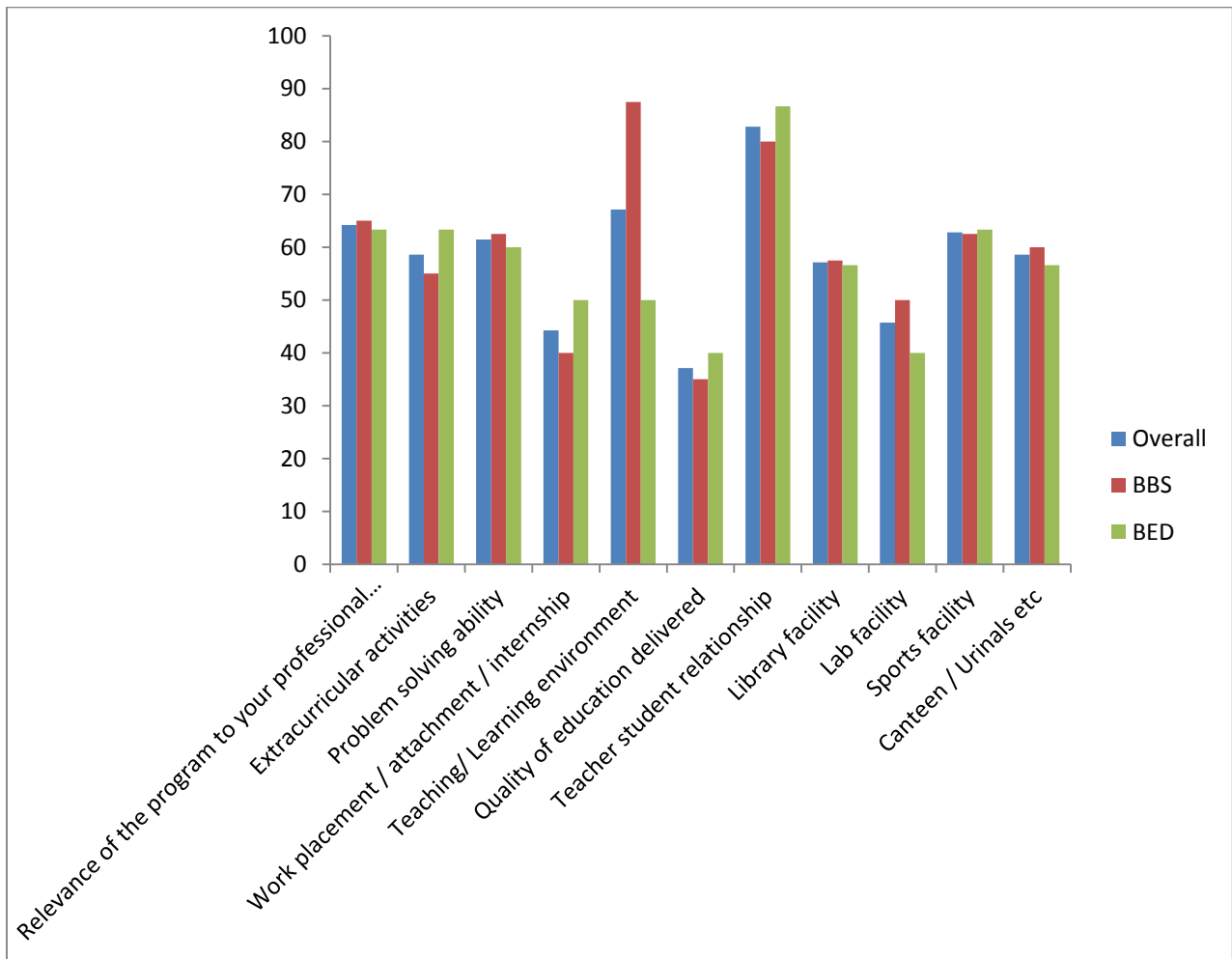

**Figure 10: Contribution of Program of Study of Graduate**

This table describes the rating of graduates on Relevance of the program to the graduate requirements of the institution relating with its quality education delivery mechanism

**Table 13:Relevance of the program to the professional requirements**

<b>Response</b>	<b>Total</b>		<b>BBS</b>		<b>B.Ed.</b>	
	<b>No.</b>	<b>%</b>	<b>No.</b>	<b>%</b>	<b>No.</b>	<b>%</b>
Very Much	4	28.5	2	25	2	33
Much	9	64.2	6	75	3	50
A little	1	7.3	0	-	1	17
Very little	0	0	0	-	-	-
Not at all	0	0	0	-	-	-
Total	14		8		6	

Field survey 2019

64.2 % of respondent Relevance of the program to your professional requirements as strength of their program of study. In this context 65% and 63.3% was observed in BBS and BED respectively as a higher level of satisfaction. (Table13 and Table 12)

This figure shows that the rating of graduates on Relevance of the program to the graduates requirements

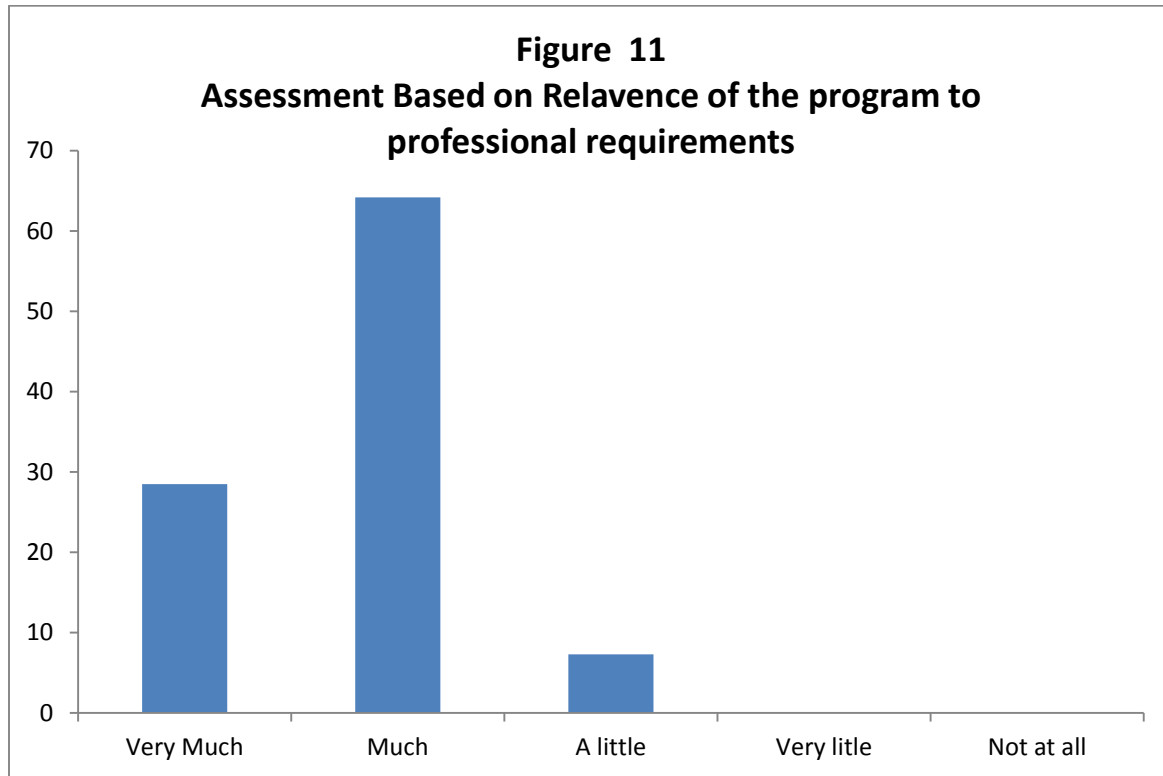

The following table shows the extent of extracurricular activities as strength of their program of study.

**Table 14**  
**Extracurricular activities**

Response	Total		BBS		B.Ed.	
	No.	%	No.	%	No.	%
Very Much	3	21.5	1	12.5	2	25
Much	7	50.0	4	50	3	50
A little	4	28.5	3	37.5	1	12.5
Very Little	0	0	0	0	0	0
Not at all	0	0	0	0	0	0
Total	14		8		6	

Field survey 2019

58.57.0% of respondents found the extent of extracurricular activities as strength of their program of study. An above average level of satisfaction was obtained from those in BBS and BED as 55% and 63.3.% respectively. (Table 14 and Table 12).

Following figure shows the extent of extracurricular activities as strength of their program of study.

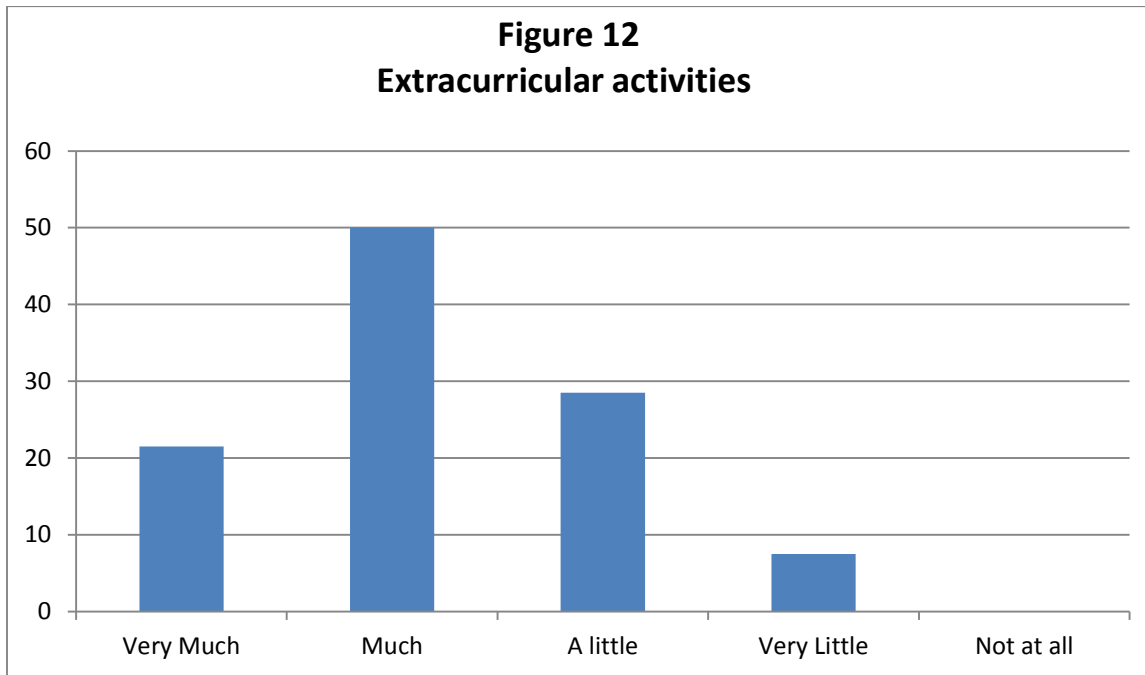

The following table shows the problem solving ability as a strength of their program of study.

**Table 15: Problem solving ability**

Response	Total		BBS		B.Ed.	
	No.	%	No.	%	No.	%
Very Much	4	28.57	3	37.5	1	16.67
Much	8	57.14	4	50	4	75.0
A little	1	7.12	1	0	1	12.5
Very Little	1	7.12	0	12.5		
Not at all	0	0	0	0		
Total	14		8		6	

Field survey 2019

59% of respondents found the problem solving ability as a Strength of their program of study. (Table 16 and Table 12)

The following figure shows the problem solving ability as a strength of their program of study.

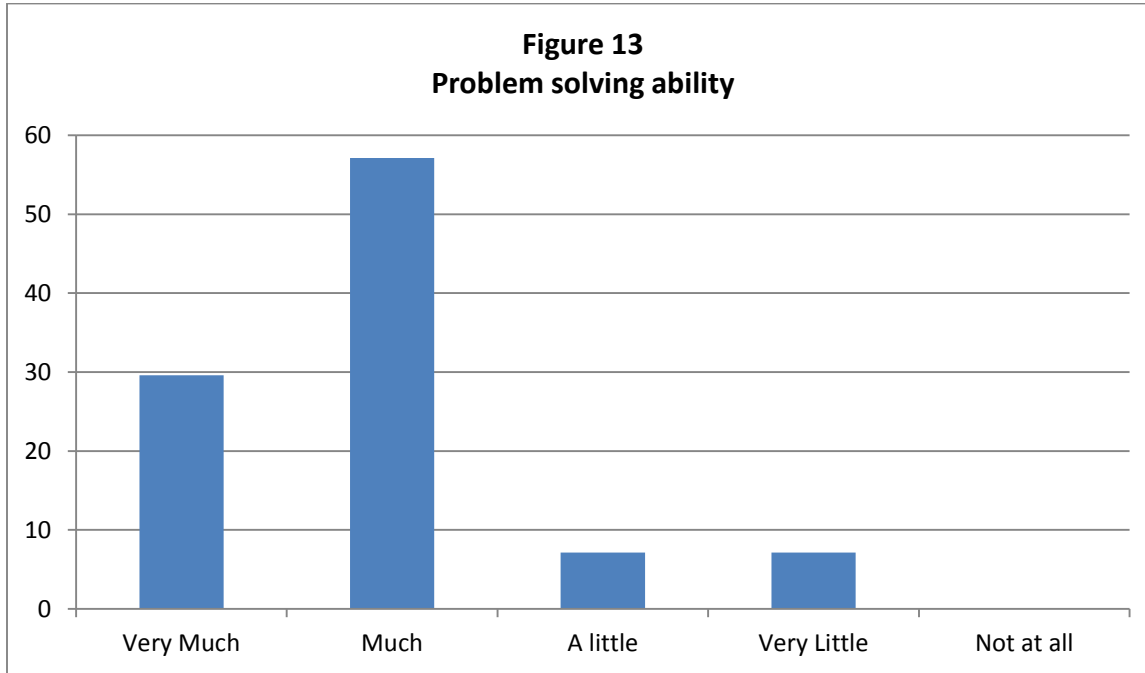

The Following table describes that work placement a part of the program of study

**Table 16: Work placement/ attachment/ internship**

Response	Total		BBS		B.Ed.	
	No.	%	No.	%	No.	%
Very Much	2	14,29	1	12,5	1	16.67
Much	3	21,43	1	12.5	2	33.33
A little	5	35.7	3	37.5	2	33.33
Very Little	4	28.57	3	37.5	1	16.67
Not at all	0	0	0	0	0	0
Total	14		8		6	

Field survey 2019

44.28% of respondents assessed that work placement a part of the program of study ie very much 14.29%, much 21.43%, a little 35.7% whereas 28.57% not relevant or not satisfied at all. In BBS 12.5% and very much 12.5%,much 35.7%, a little 28.57% respondents were satisfied respectively and unsatisfied. In B.Ed., in very much it was 16.67% whereas it was 33.33% in much, 33.33% in a little and 16.67% not satisfied. (Table 15 and Table 12)

The Following figure describes that work placement a part of the program of study

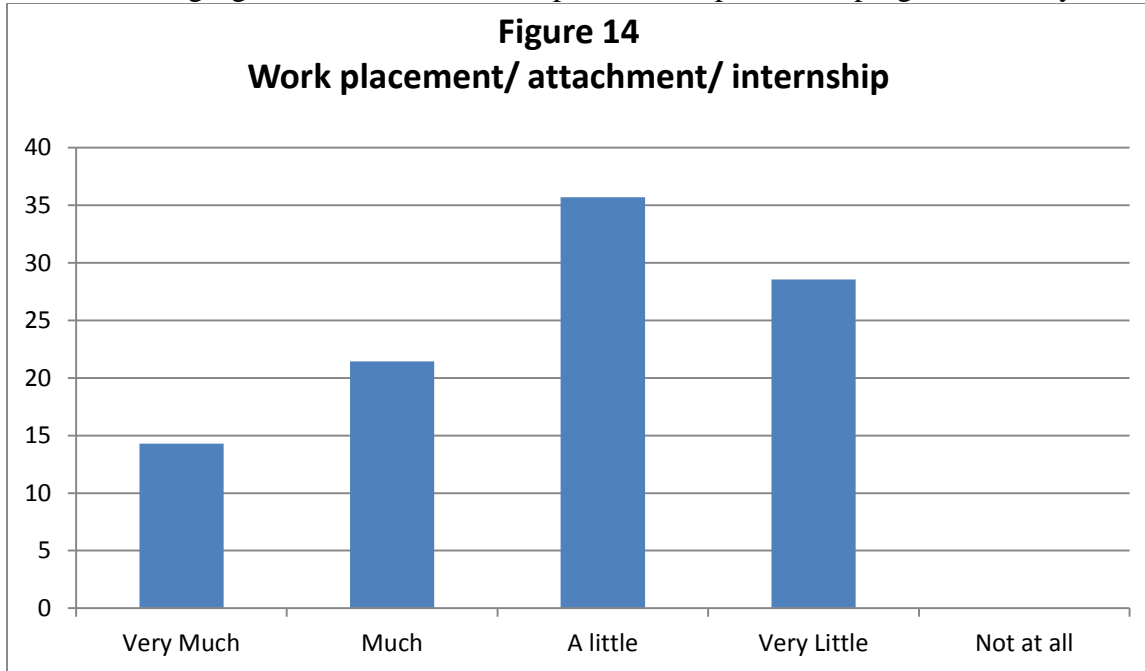

The table given below deals that teaching learning environment plays vital role of the program of study Table 17:

Teaching/ learning environment

Response	Total		BBS		B.Ed.	
	No.	%	No.	%	No.	%
Very Much	5	35.7	3	37.5	2	33.33
Much	9	64.29	5	62.5	4	66.77
A little	0	0	0	0	0	0
Very Little	0	0	0	0	0	0
Not at all	0	0	0	0	0	0
Total	14		8	0	6	

Field survey 2019



Out of total respondents 67.14% thought that teaching learning environment plays vital role of the program of study ie very much 36.7 %, much 64.29%, a little 0% whereas 0% not satisfied at all. In BBS 37.5% respondents were satisfied very much, 62.5% were much, 0% a little and none of unsatisfied. Similarly in Bed. among the respondents in very much it was 33.33% whereas it was 66.7% in much, 0% in a little and 0% not satisfied. (Table 17 and Table 12)

The figure given below deals that teaching learning environment as a strength of the program of study

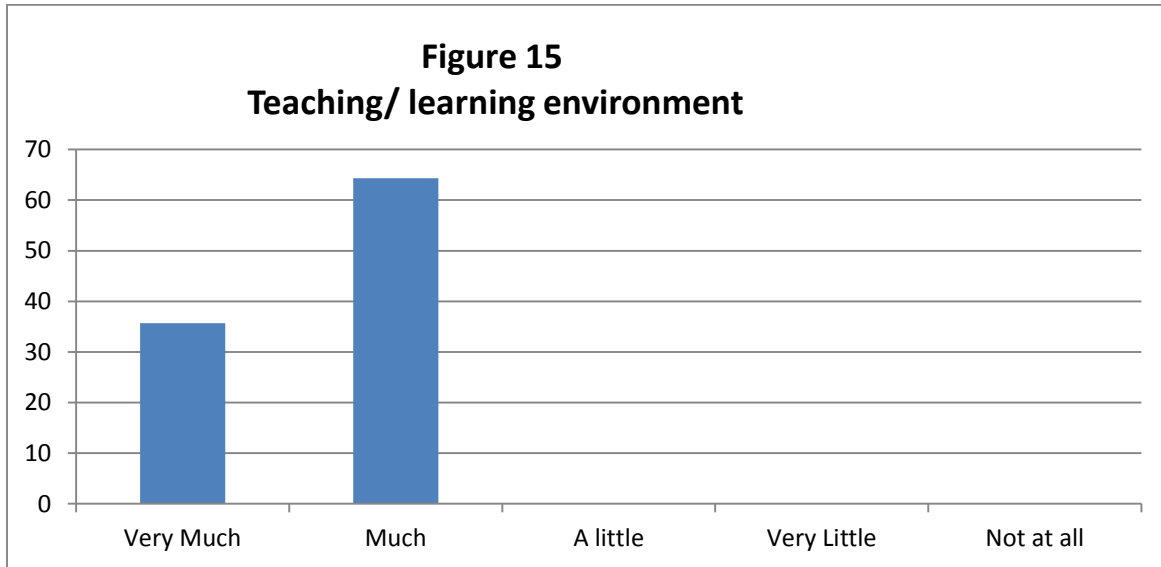

This table indicated that the program of study assure the quality of education delivered

Table 18

**Quality of education delivered**

Response	Total		BBS		B.Ed.	
	No.	%	No.	%	No.	%
Very Much	2	14.3	2	25.00	0	0
Much	1	7.1	0	0	1	16.67
A little	4	28.57	0	0	4	66.67
Very Little	7	50.00	6	75.00	1	16.67
Not at all	0	0	0		0	0
Total	14		8		6	

Field survey 2019

In total 37.14% of respondents indicated that the program of study assure the quality of education delivered ie very much 14.3%, much 7.1%, a little 28.57% whereas 50% not satisfied at all. In BBS 25% respondents were satisfied very much and 0% much respectively 0% a little and 75% unsatisfied. In B.Ed. in very much it was 0% whereas it was 16.67% in much, 66.67% in a little and 0% not satisfied. (Table 18 and Table 12)

The following table shows that the program of study assure the quality of education delivered

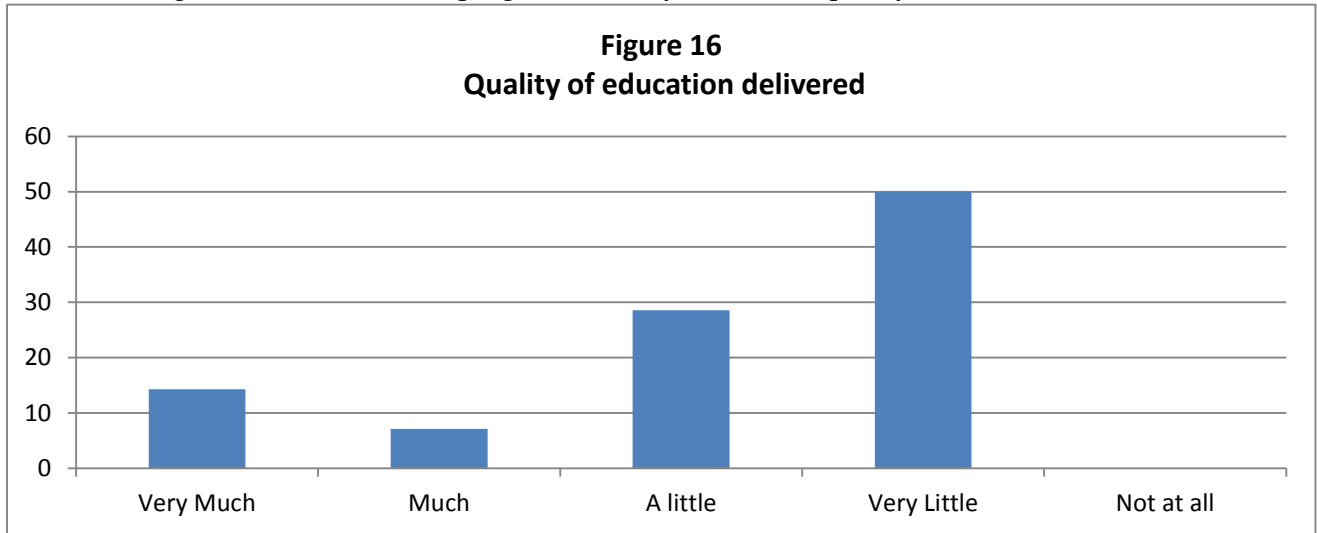

This table indicated that the teacher student relationship's role in their program of study

**Table 19: Teacher Student relationship**

Response	Total		BBS		B.Ed.	
	No.	%	No.	%	No.	%
Very Much	12	85.7	6	75	6	100
Much	1	7.1	1	12.5	0	0
A little	0	0	1	12.5	0	0
Very Little	1	7.1	0	0	0	0
Not at all	0	0	0	0	0	0
Total	14		8		6	

Field survey 2019

The biggest number of respondents (82.8%) indicated that the teacher student relationship plays vital role in their program of study ie very much 85.7%, much 7.1%, a little 0% whereas 7.1% not satisfied at all. In BBS 75% respondents were satisfied very much,12.5% much,12.5% a little and0% not satisfied. In BED 100% respondents were satisfied and none are unsatisfied.(Table-19 and Table 12)

This figure deals that the teacher student relationship's role in their program of study

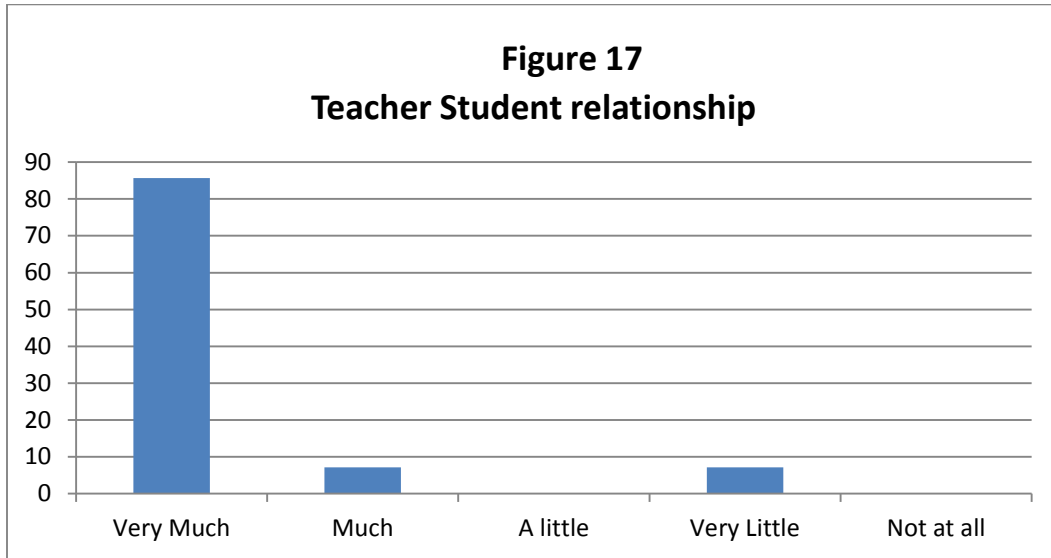

This table assessed that the program of study was facilitated by library facilities

**Table 20: Library facility**

Response	Total		BBS		B.Ed.	
	No.	%	No.	%	No.	%
Very Much	3	21.4	2	25	1	16.67
Much	7	50	4	50	3	50
A little	3	21.4	1	12.5	2	33.33
Very Little	1	7.1	1	12.5	0	0
Not at all	0	0	0	0	0	0
Total	14		8		6	

Field survey 2019

In total 57.4% of respondents assessed that the program of study was facilitated by library facilities ie very much 21.4%, much 50%, a little 21.4% whereas 7.1% not satisfied at all. In BBS 25% very much 50% much and 12.5% respondents were a little and 12.5% were very little and none of unsatisfied. In B.Ed. in very much it was 16.67% whereas it was 50% in much, 33.33% in a little and None of unsatisfied. (Table 20 and Table 12)

This figure pointed that the program of study was facilitated by library facilities

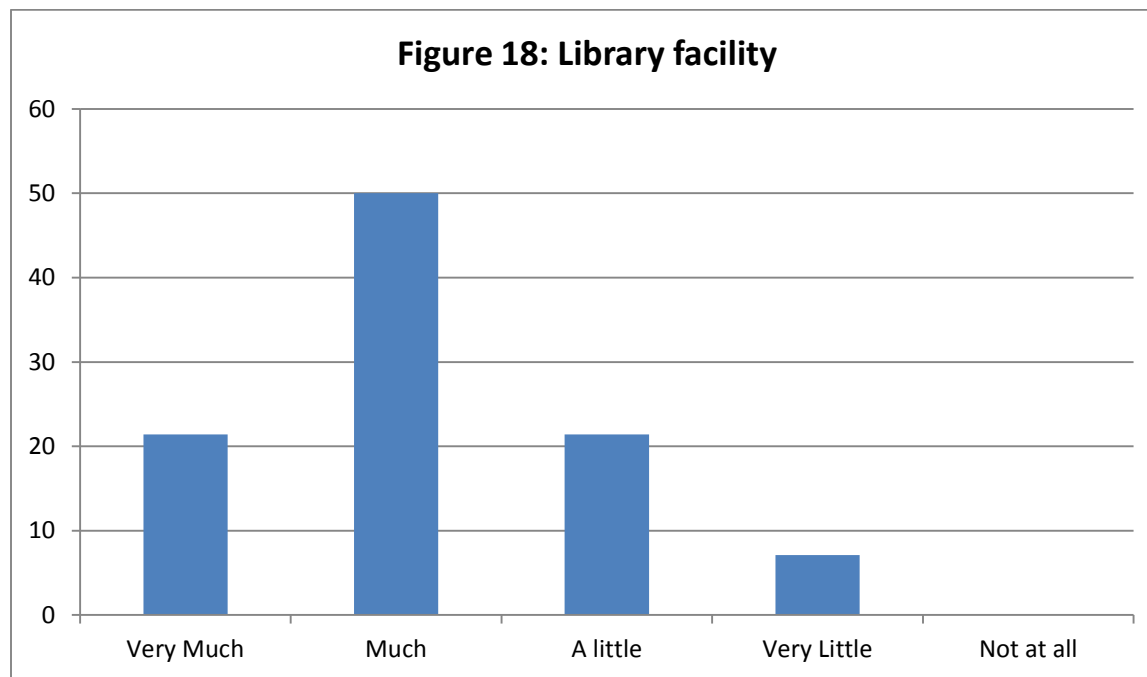

This table indicated that the program of study was affected by Lab facilities

**Table 21: Lab facility**

Response	Total		BBS		B.Ed.	
	No.	%	No.	%	No.	%
Very Much	0	0	0	0	0	0
Much	5	35.71	5	62.5	0	0
A little	8	57.14	2	25	6	100
Very Little	1	7.1	1	12.5	0	0
Not at all	0		0	0	0	0
Total	14		8		6	

Field survey 2019

45.7% of respondents indicated that the program of study was enhanced by Lab facilities ie very much 0%, much 35.7%, a little 57.14% whereas 7.1% not satisfied at all. In BBS 0% very much,62.5% much and a little 25% and 12.5% were unsatisfied. In B.Ed. in very much it was 0% whereas it was 0% in much, 100% in a little and 0% not satisfied. (Table 21 and Table 12)

This figure indicated that the program of study was affected by Lab facilities

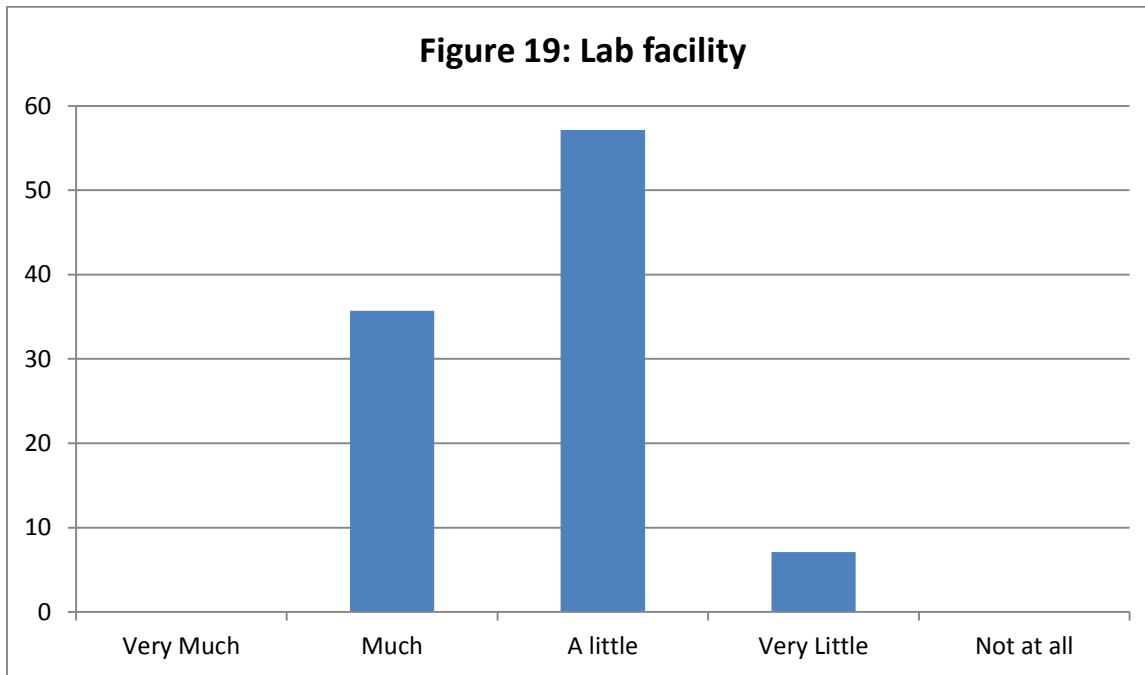

This table indicated that sports was a part of the program of study

**Table 22: Sports facility**

Response	Total		BBS		B.Ed.	
	No.	%	No.	%	No.	%
Very Much	6	42.8	3	37.5	3	50
Much	4	28.5	3	37.5	1	16.67
A little	4	28.57	2	25	2	33.33
Very Little	0	0	0	0	0	0
Not at all	0	0	0	0	0	0
Total	14		8		6	

Field survey 2019

In total 62.8% of respondents indicated that sports was a part of the program of study ie 42.8% very much ,28.5% much, 28.57% a little ,0% very little and not satisfied at all. In BBS 0% very much,37.5%, 37.5% much and a little 0% and unsatisfied. In B.Ed. in very much it was 50% whereas it was 16.67% in much, 33.33% in a little and 0% not satisfied. (Table 22 and Table 12) This table shows that sports was a part of the program of study

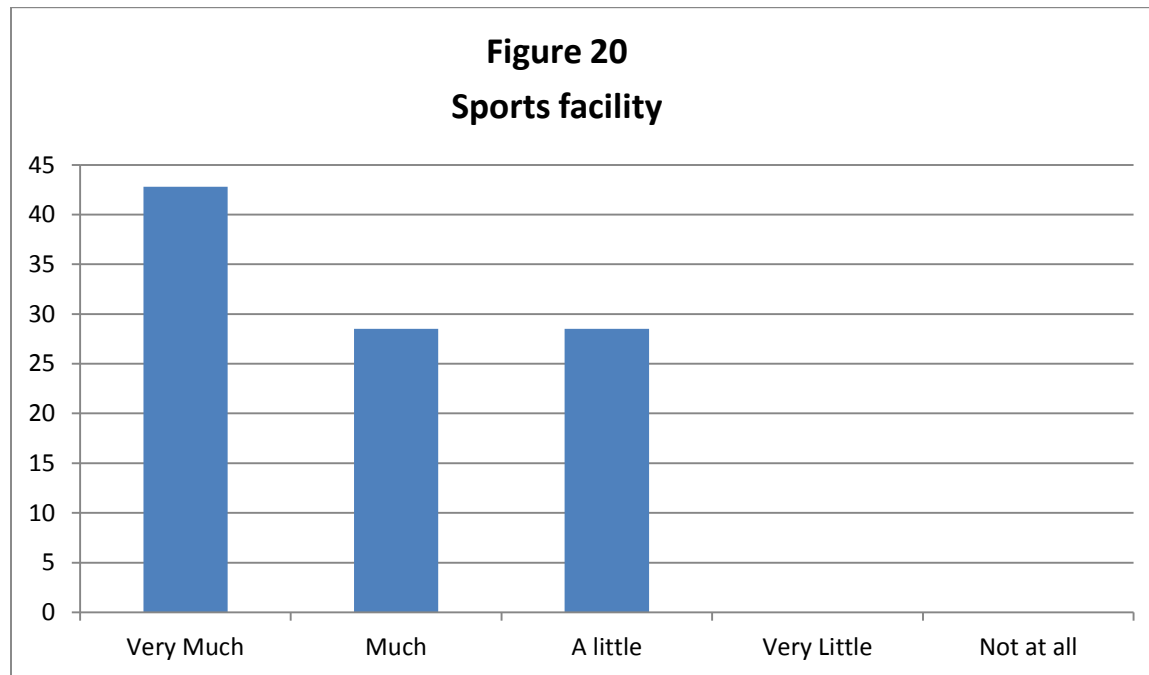

This table is the assessment of the graduates of the canteen/urinals was the strength of institution

**Table 23: Canteen / Urinals etc**

Response	Total		BBS		B.Ed.	
	No.	%	No.	%	No.	%
Very Much	1	7.1	0	0	1	16.67
Much	11	78.5	8	100	3	50
A little	2	14.3	0	0	2	33.33
Very Little	0	0	0	0	0	0
Not at all	0	0	0	0	0	0
Total	14		8		6	

Field survey 2019

In total 58.57% of respondents assessed that the canteen/urinals was the strength of institution. ie very much 7.1%, much 78.5%, a little 14.3% whereas 0% not satisfied at all. In BBS 100% much and 0% unsatisfied. In B.Ed. in very much it was 16.67% whereas it was 50% in much, 33.33% in a little and 0% not satisfied. (Table 23 and Table 12)

This table indicated the suggestion and Recommendation of Graduates for betterment of the college

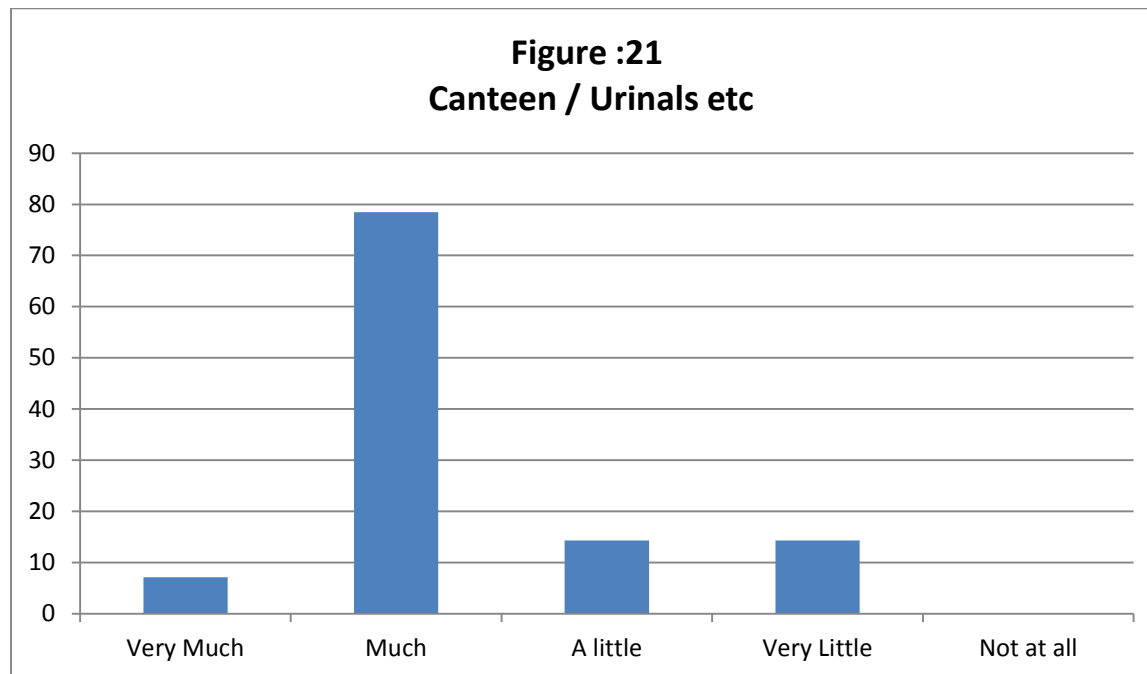

This table indicated the suggestion and Recommendation of Graduates for betterment of the college

**Table24: Suggestion and Recommendation of Graduates for betterment of the college.**

<b>Suggestions &amp; recommendation</b>	<b>Total</b>	<b>%</b>	<b>BBS</b>	<b>%</b>	<b>BED</b>	<b>%</b>
Enhance Teaching learning environment	2	14.3	1	12.5	1	16.67
Provide pure drinking water	1	7.1	1	12.5	0	0
Increase library	4	28.57	2	25	2	33.33
Increase sports facilities	2	14.3	1	12.5	1	16.67
Increase Canteen facilities	4	28.57	2	25	2	33.33
Increase Lab facilities	1	7.1	1	12.5	0	0
<b>Total</b>	<b>14</b>		<b>8</b>		<b>6</b>	

The future of the institution was measured through another specific question. The data showed that (14.3%) of respondents to give suggestion of enhance Teaching learning environment, 7.1% Providing pure drinking water, 28.57% Increase library and Canteen facilities, 7.1% lab facilities, 7.1% sports facilities (Table 24) .

This table indicated the suggestion and Recommendation of Graduates for betterment of the college

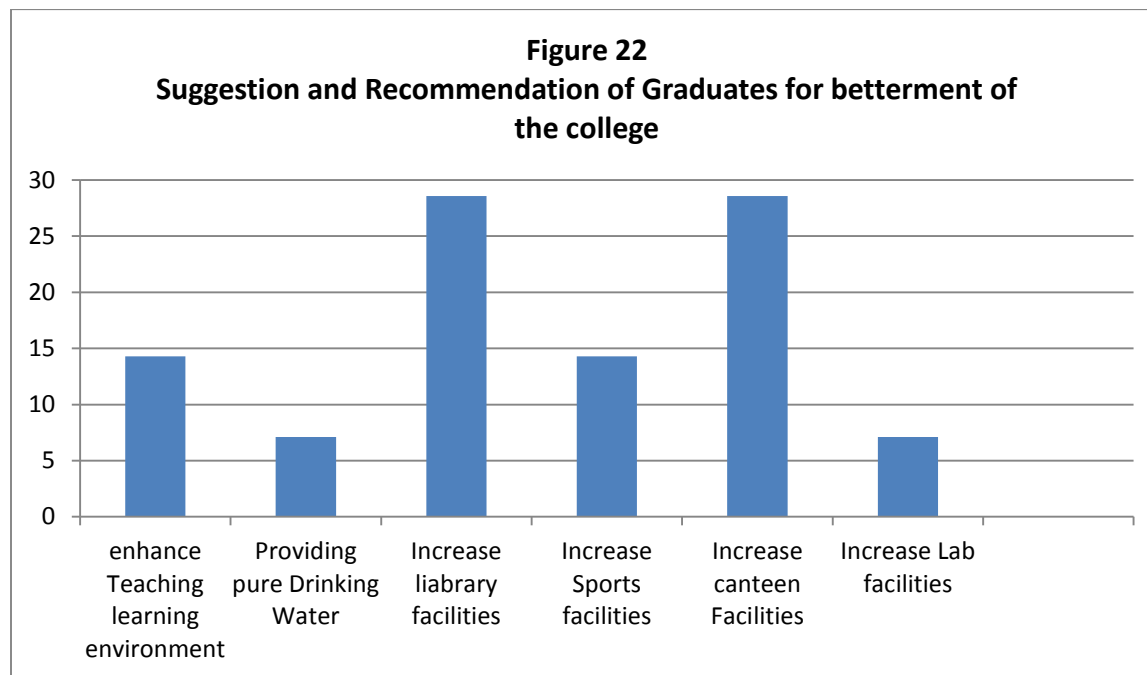

This table describes the Possible Contribution of Graduates

**Table 25: Possible Contribution of Graduates for the Betterment of the College.**

Contributions	Total	%	BBS	%	BED	%
Financial support for needy students	2	14.3	2	25	1	16.67
Support through Alumni	5	35.7	4	50	3	50
Support of teaching materials	5	35.7	2	25	1	16.67
scholarship fund	1	7.1	0	0	1	16.67
Donate the unused Book	1	7.1	0	0	0	0

Field survey 2019



The expected contribution was gauged through another direct question. The result showed that the highest percentage 35.7% of respondents purposed for the financial support through Alumni and support for teaching materials where as it was less in others such as financial support (14.3%), Create scholarship fund and donate for unused books(7.1%) in the year 2018 (Table 25).

This figure describes the Possible Contribution of Graduates

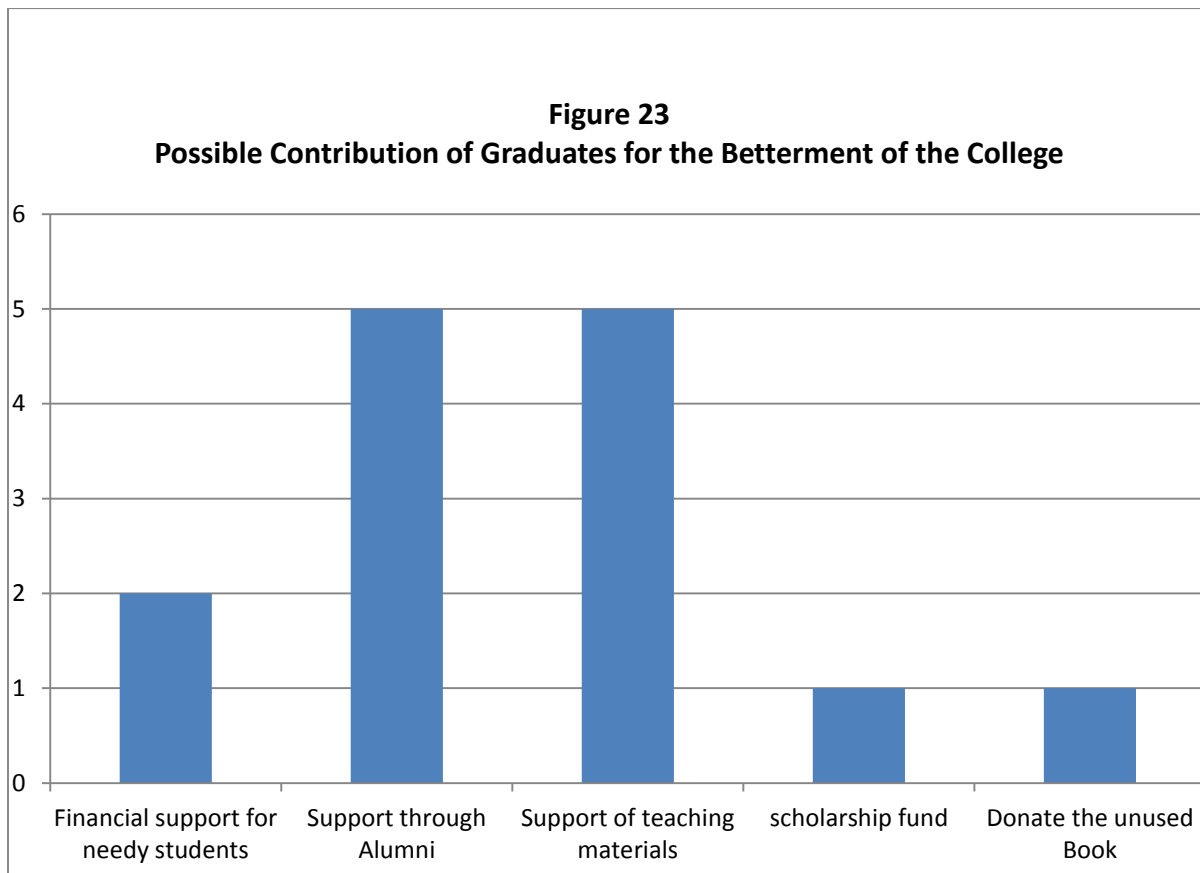

## CHAPTER 3

### MAJOR FINDINGS

Tracer studies constitute one form of empirical study, which can be considered an appropriate means of evaluating the results of the education given institution. It brings together certain basic types of information concerning the level of employment, unemployment and underemployment amongst graduates. Also, it analyzes the ratings of the graduates on several teaching-learning dimensions: relevance of program to the professional jobs, extracurricular activities, problem solving ability, work placement/attachment/internship, teaching/learning environment, and quality of education delivered, teacher student relationship, library and lab facility, sport facility, and canteen/urinals prescribed by UGC . The major findings of the study are described below:

- Out of 14 graduates participated in the survey 8(57.14%) were from the Management Faculty, 57.5 % of respondents belonging to upper Cast (brahmin and chhetri) and 79% were female.
- The mean age of the graduates is 24.9 with education graduation being on average slightly older than Management ones. (Bed 26.6 yrs and BBS 23.6 yrs)
- 100% of employed respondents were working full-time, none were working part-time and above two third ie 75% were working in the private sector.
- 71.43% of the respondents were unemployed compare to 28.57% who were employed.
- Out of total respondents (14) , Minority 28.5% were enrolled for further study for master degree and all of these are in management faculty (MBS).
- Out of total employed graduates 50% are upper cast.
- 50% graduates of both faculties (Management and education) have a job.
- Regarding the occupation, most of the graduates are working as a teacher.
- Overall teaching learning environment of ssc has both strengths and weaknesses. Findings of the study explored that majority of the respondents were satisfied with teacher student relation (82.8%), quality of education delivered (67.14%), teaching learning environment (67.14%), relevance of the program to professional jobs (64.2%) . These are the strengths of SSC. But this report also reveals that some respondents were less satisfies with library facility, work placement Problem solving ability, extracurricular activities and canteen/urinal facilities, lab and sports facility.
- 14.29% of respondents to give suggestion of enhance teaching learning environment, 57.14% Increase library and Canteen facilities ,14.29% Sports ,7% Lab facilities,7 % Drinking Water.
- 71.4% of respondents committed to contribute to the college for the financial support through Alumni and support for teaching materials

## **CHAPTER 4**

### **IMPLICATIONS TO INSTITUTIONAL REPORT**

This college has a vital role to make education accessible to the community. SSC has been producing dexterous human resource. Majority of the graduates were employed in different private and government organization. Because of the pressure of globalization, employee should be more competitive. The demand of labour market will be changing in the future. Keeping this thing in mind we should establish linkage between curricula and the changing needs of labour market to enable students to perform future jobs. Moreover, none of the respondents were found self-employed indicating relatively low contribution of the campus in preparing entrepreneurs. Therefore, emphasis should be given to develop entrepreneurial skills of the students and operate their own enterprises. In the process, SSC has initiated BCA and MBS so that they can be good entrepreneurs in upcoming future.

This graduate tracer study is mainly a survey, intended to trace graduates from their school of origin to their place of employment, self-employment and further study. This information gives guideline to the institution and adopts new technique such as in pedagogies that enhance skills of the students along with the knowledge so that they would be high performer at their workplaces in the future. Minority of the respondents were satisfied with problem solving ability, relevancy of the program to professional job, teacher student relationship, quality of education delivered and work placement/internship. Moreover, the institution should develop relationship with the employers' institutions in local and national level to identify the future skills need of the market so that it will be easier to arrange internship, job placement and graduates can be entrepreneur in the future.

# **CHAPTER 5**

## **CONCLUSION & RECOMMENDATIONS**

### **5.1 Conclusion**

SSC has been running different academic programs with the objective of producing competent human resources for the employers. By providing quality education with the facility of modern technology, the college has done a great effort for the nation building process. Moreover, it also strives to prepare entrepreneurs for the society.

The numbers of graduates of female are higher than the male shows that female are gradually attracted toward higher education. Moreover, graduates student belonging to different cast like Gurung (36.0%), Brahmin(28.5% ), Chhetri (14.2%), Tamang (14.2%) and Dalit (7.0%) shows that the number of Janajati (Gurung and Tamang) are higher than other cast in SSC college.

Majority of the graduates were employed in private organization whereas, very few were employed in government sector. It shows that SSC has been producing competent human resources to uplift the Nepalese economy; however, its contribution in preparing entrepreneurs is not satisfactory.

Most of the graduates from this college are from the management stream and Majority of them were enrolled in master degree in management stream indicating the popularity of the management stream in the Nepalese market.

SSC has been providing many facilities on which Majority of the respondents were satisfied. The facilities like teacher student relationship, teaching/learning activities, quality of education delivered, relevance of programs to professional jobs and work placement/attachment/internship facilities shows the strength of SSC. However, this study also pointed out need of improvement in extra-curricular activity, canteen/urinal facilities, library facility, lab and sport facilities. Minority of the respondents were satisfied with those indicators.

## 5.2 Recommendations

Based on data analysis and findings, following recommendations are made:

- i) Recommended to give priority on new course and program.
- ii) Recommended to provide the proper physical facilities.
- iii) Recommend to launch IT courses in the stream of BBS, B.Ed.
- IV) Recommend to provide Library facility.
- v) Recommended to add extracurricular activities and sport facilities
- vii) Recommend to launch scholarship fund to assist the needy student.
- viii) Recommend to conduct the census covering all the passed out graduates to obtain the complete data and comprehensive results.
- ix) Priority should be given to develop research skill of the graduates.
- x) Use the teaching material in class room activities.
- xi) Recommend for activating Alumni.
- xii) Recommended to manage the remedial courses.
- xiii) Recommended to explore new curricula and pedagogies, which would be helpful for producing competent entrepreneurs and human resources